

ZONING ORDINANCE OF THE CITY OF MONTEVALLO

ARTICLE 21. SIGN REGULATIONS

Section 21.01. General Provisions

The purpose of this Article is to provide the minimum control of signs that ensures the protection of the public safety and general welfare. These provisions are intended to lessen the hazards to pedestrian and vehicular traffic, prevent unsightly and detrimental development which has a blighting influence upon the community, prevent signs from reaching such excessive size or numbers that they obscure one another to the detriment of all concerned, preserve the general character and aesthetic quality of the various areas within the City of Montevallo and promote a positive City image reflecting order, harmony and pride.

Section 21.02. Definitions.

Words and phrases used in this Article shall have the meanings as set forth in this section. Words and phrases not defined in this section but defined elsewhere in the zoning regulations shall be given the meanings as set forth in such regulations. All other words and phrases shall be given their common, ordinary meaning unless the context clearly requires otherwise.

Administrator. The person or his/her duly authorized representative designated by the City Council to administer this Ordinance.

Advertising. Sign copy intended to directly or indirectly promote the sale or use of a product, service, commodity, entertainment, or real or personal property.

Animated Sign. Any sign that uses movement or change of lighting to depict action or create a special effect or scene.

Awning Sign. A sign directly painted or otherwise directly affixed to an awning.

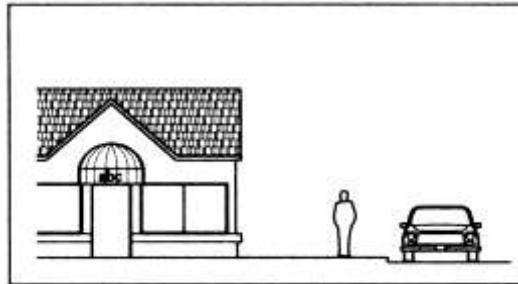

Banner. Any sign of lightweight fabric or similar material that is permanently mounted to a pole or building by a permanent frame at one or more edges. National flags, state or municipal flags or the official flag of any institution or business shall not be considered banners.

Building Marker. Any sign indicating the name of a building, date of construction and incidental information, which is cut into a masonry surface or made of bronze or other permanent material.

Canopy Sign. A sign directly painted or otherwise directly affixed upon a building canopy.

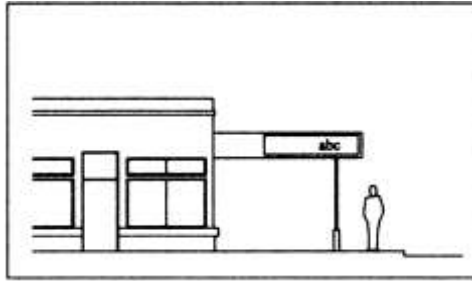

Changeable Copy Sign. A sign or portion thereof with characters, letters, or illustrations that can be changed or rearranged without altering the face or surface of the sign. A sign on which the message changes more than eight (8) times a day shall be considered a animated sign and not a changeable copy sign. A sign on which the only copy that changes is an electronic or mechanical indication of the time and temperature shall be considered a "time and temperature" portion of the sign and not a changeable copy sign.

Commercially Developed Parcel. A parcel of property on which there is at least one walled and roofed structure used, or designed to be used, for other than residential or agricultural purposes.

Commercial Occupant. A commercial use, i.e., any use other than residential or agricultural.

Construction Sign. A temporary sign indicating the names of architects, engineers, landscape architects, contractors, and similar artisans involved in the design and construction of a structure or project only during the construction period and only on the premises on which the construction is taking place.

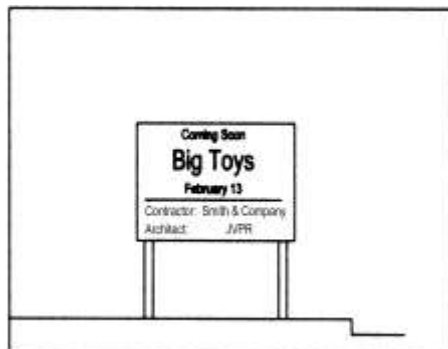

Copy. The linguistic or graphic content of a sign.

Double-faced Sign. A sign, both sides of which are visible and used as signs. The sign area of a double-faced sign, where the two sign faces are never greater than twenty-four (24) inches apart, shall be computed as the area of one sign face, whichever is greater. When the two sign faces are greater than twenty-four (24) inches apart, the sign area shall be computed as the sum of both faces.

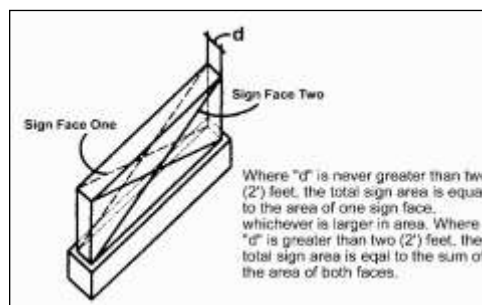

Electric Sign. Any sign containing electric wiring.

Erect a Sign. To construct, reconstruct, build, relocate, raise, assemble, place, affix, attach, create, paint, draw, or in any other way bring into being or establish a sign. It shall not include any of the foregoing activities when performed as an incident to the change of message, or routine maintenance.

Flashing Sign. A sign with an intermittent, repetitive, or flashing light source.

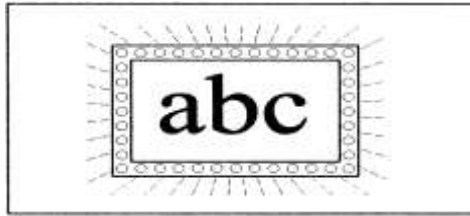

Frontage. The length of the property line of any one parcel along a street on which it borders.

Illuminated Sign. A sign which contains a source of light or which is designed to reflect light from an artificial source including indirect lighting, neon, incandescent lights, back-lighting, and shall also include signs with reflectors that depend upon automobile headlights for an image.

Illuminated Sign. A sign which contains a source of light or which is designed to reflect light from an artificial source including indirect lighting, neon, incandescent lights, back-lighting, and shall also include signs with reflectors that depend upon automobile headlights for an image.

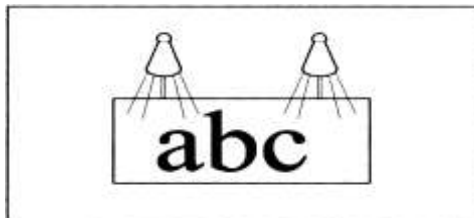

Marquee. A structure projecting from and supported by a building which extends beyond the building line or property line and fully or partially covers a sidewalk, public entrance or other pedestrian way.

Monument sign. A monument sign is a freestanding sign, a wall with a sign permanently attached, or a decorative wall that incorporates a sign. Monument signs are typically constructed low to the ground from natural materials such as stone, brick or wood and surrounded with additional landscape plantings. The sign copy area is attached directly to the base of the sign or otherwise located close to the ground and may be indirectly illuminated. A monument sign shall be no more than ten (10) feet in height except where further restricted and shall have the lowest portion of its sign face no more than three (3) feet above the ground. This is also commonly referred to as a Ground Sign.

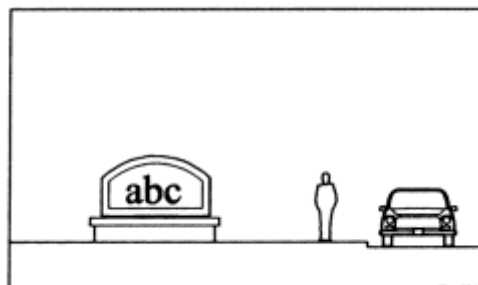

Multiple Occupancy Complex. A parcel of property or parcels of contiguous properties, existing as a unified or coordinated project, with a building or buildings housing more than one occupant.

Nameplate Sign. A wall sign indicating the name and/or address of a business.

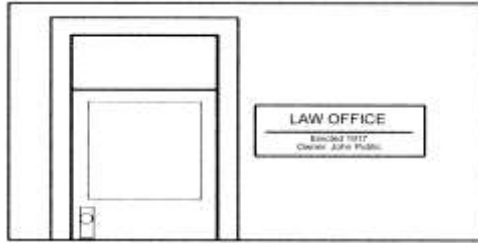

Parcel. A unit of land within legally established property lines. If, however, the property lines are such as to defeat the purposes of these sign regulations or lead to absurd results, a "parcel" may be as designated for a particular site by the Administrator.

Pennant. Any lightweight plastic, fabric, or other material, whether containing a message or not, suspended from a rope, wire, string, or other similar device, designed to move in the wind.

Pole Sign. A freestanding sign mounted above one or more vertical structural members (Also referred to as a *Pylon Sign*).

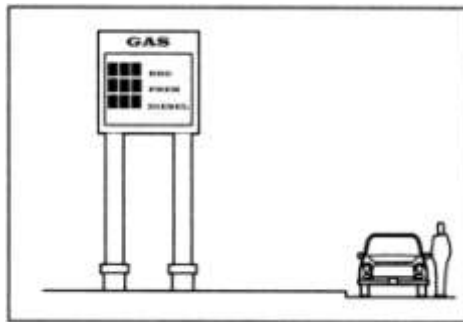

Portable Sign. Any sign not permanently attached to the ground or other permanent structure, or a sign designed to be transported, including, but not limited to, signs designed to be transported by means of wheels; signs converted to A-frames or T-frames; menu or sandwich board signs; balloons or other inflatable devices used as signs; umbrellas used for advertising; and signs attached to or painted on vehicles parked and visible from the public right-of-way, unless such vehicle is used in the normal day to day operations of the business.

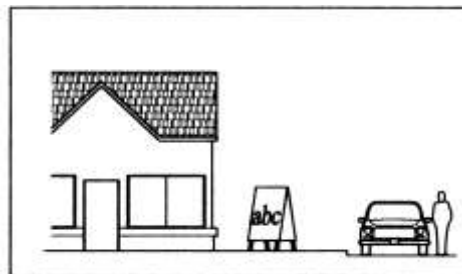

Projecting Sign. A sign affixed to a building or wall in such a manner that its leading edge extends more than six (6) inches beyond the surface of the building or wall.

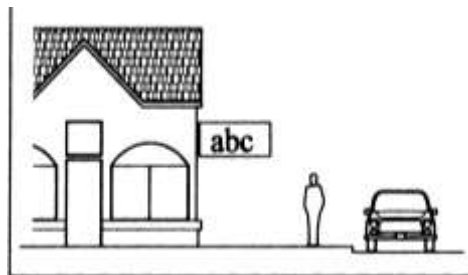

Roof Line. A horizontal line intersecting the highest point or points of a roof.

Roof Sign. A sign that is mounted on the roof of a building or which is wholly dependent upon a building for support and which projects above the highest point of a building with a flat roof, the eave line of a building with a gambrel, gable, or hip roof, or the deck line of a building with a mansard roof.

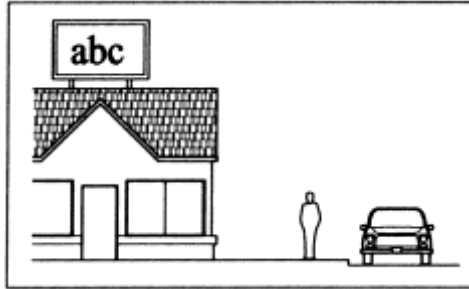

Sign. Any writing, pictorial presentation, number, illustration, decoration, flag, banner, pennant, or other device which is used to announce, direct attention to, identify, advertise or otherwise make anything known. The term sign shall not be deemed to include the terms "building" or "landscaping" or any architectural embellishment of a building not intended to communicate information.

Sign Face Area. The area of any regular geometric shape, which contains the entire surface area of a sign upon which copy may be placed.

Sign Structure. Any construction used or designed to support a sign.

Street. A public or private right of way for vehicular traffic, including highways, thoroughfares, lanes, roads, ways, and boulevards.

Tenant Sign. A ground sign containing the name of a multi-tenant business center and typically containing the names of the tenants within the development.

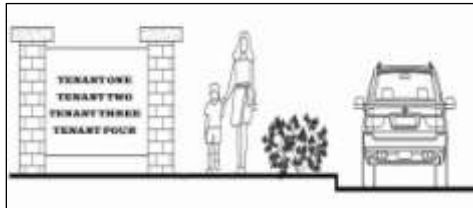

Unit. That part of a multiple occupancy complex housing one occupant.

Vehicle Sign. Any sign affixed to a vehicle.

Wall Sign. A sign displayed upon or attached to any part of the exterior of a building, including walls, windows, doors, parapets, marquees and roof slopes of forty-five (45) degrees or steeper.

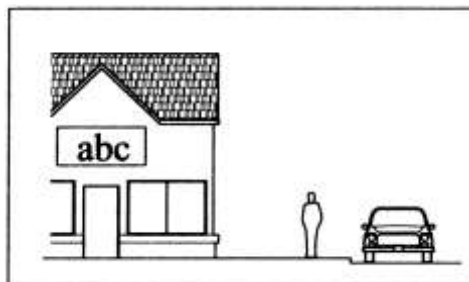

Window Sign. Any sign, picture, symbol, or combination thereof designed to communicate information about a business, commodity, event, sale, or service that is placed inside or upon a window and is visible from the exterior of the window.

Section 21.03. Measurement Determinations.

A. Number of Signs.

In general, the number of signs shall be the number of non-contiguous sign faces. Multiple non-contiguous sign faces may be counted as a single sign if all the sign faces are included in the geometric figure used for determining the sign area.

B. Sign Face Area.

1. Individual Signs.

The sign face area of individual signs shall be computed by means of the smallest square, circle, rectangle, triangle or combination thereof that will encompass the extreme limits of the writing representation, emblem, or other display, together with any material or color forming an integral part of the background of the display or used to differentiate the sign from the backdrop or structure against which it is placed. This does not include the supporting framework, bracing, or decorative fence or wall when such fence or wall otherwise meets applicable regulations and is clearly incidental to the display itself.

a. Multi-faced Signs.

The sign face area of a sign with more than one face shall be computed by adding together the area of all sign faces visible from any one point. When two sign faces are placed back to back so that both faces cannot be viewed from any point at the same time and when the sign faces are part of the same sign structure and are no more than thirty-six (36) inches apart, the sign face area shall be computed by the measurement of one of the faces.

C. Sign Height.

The height of a sign shall be computed as the distance from the base of the sign at normal grade to the top of the highest attached component of the sign. Normal grade shall be construed to be the lower of existing grade prior to construction or the newly established grade after construction, exclusive of any filling, berming, mounding, or excavating solely for the purpose of locating the sign. In cases in which the normal grade cannot reasonably be determined or where the elevation of the normal grade is below the main traveled way of the adjoining street or highway along which the sign is constructed, sign height shall be computed on the assumption that the elevation of the normal grade at the base of the sign is equal to the elevation of the nearest point of the crown of the adjoining street or highway along which the sign is constructed or the grade of the land at the principal entrance to the principal structure on the parcel, whichever is lower.

D. Distance Between Signs.

The minimum required distance between signs shall be measured along street rights-of-way from the closest parts of any two signs.

E. Facade Area.

The facade area shall be measured by determining the area within a two-dimensional geometric figure coinciding with the edges of the walls, windows, doors, parapets, marquees, and roof slopes of greater than forty-five (45) degrees that form a side of a building or unit.

Measurement Determination Examples.

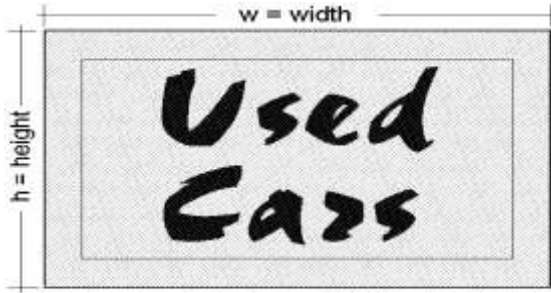

Calculating Area of a Rectangular Sign = $h \times w$

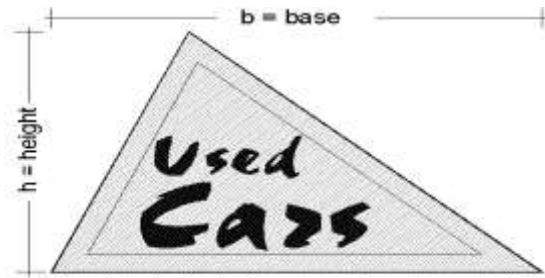

Calculating Area of a Triangular Sign = $1/2 (h \times b)$

$\pi = 3.14159$

EXAMPLE

r (radius) = 4 feet
 Area = $3.14159 \times 4 \text{ ft}^2$
 Area = 50.265 sq ft

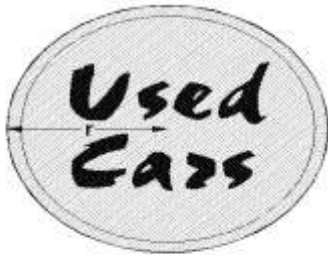

Calculating Area of a Circular Sign = $\pi \times \text{radius}^2$

$\pi = 3.14159$

EXAMPLE

A = 3 ft B = 4 ft
 Area = $3.14159 \times A \times B$
 Area = 37.699 sq ft



Calculating Area of an Elliptical Sign = $\pi \times A \times B$

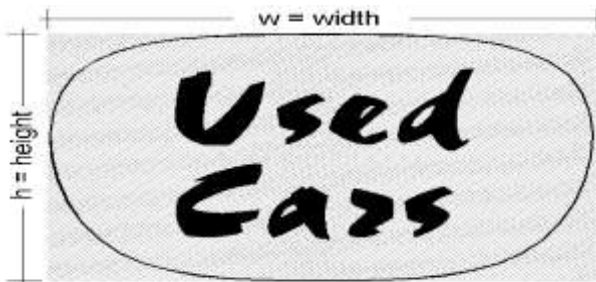

Calculating Area of an Irregular Sign = $h \times w$



Calculating Area of a Sign where Copy Exceeds Sign Area = (height of copy) x (width of copy)

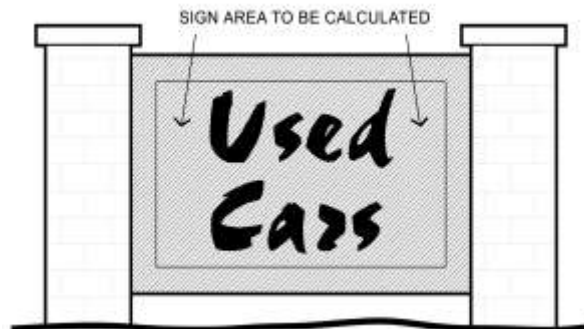

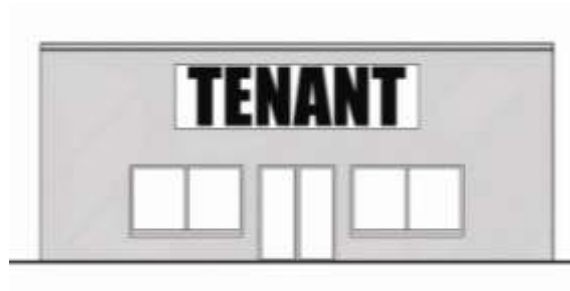

Facade Area

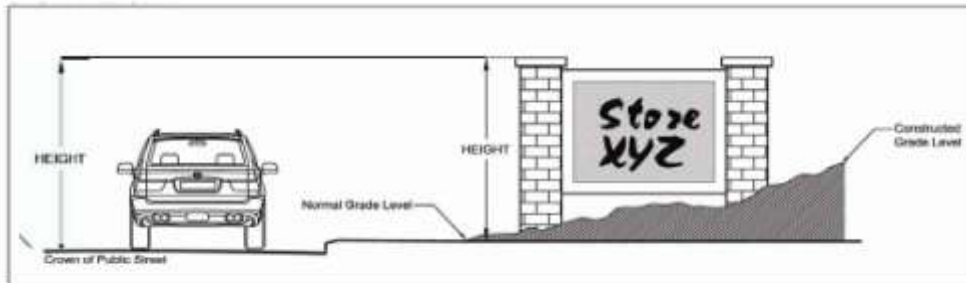

Section 21.04. Exempt Signs.

- A. The following signs are exempt from the requirement that a permit be obtained and shall not be counted toward any restriction regarding the number or area of signs permitted on a parcel provided they conform to the standards enumerated in this section and provided they are not placed or constructed so as to create a hazard of any kind:
1. Signs that are not designed or located so as to be legible from any street or adjoining property.
 2. Signs of two (2) square feet or less and signs that include no letters, symbols, logos or designs in excess of two (2) inches in vertical or horizontal dimension, provided that such sign, or combination of such signs, does not constitute a sign prohibited by these regulations.
 3. Signs necessary to promote health, safety and welfare, and other regulatory, statutory, traffic control or directional signs erected on public property with permission as appropriate from the City of Montevallo, the State of Alabama, or the United States.
 4. Legal notices and official instruments.
 5. Decorative flags and bunting for a celebration, convention, or commemoration of significance to the entire community when authorized by the City of Montevallo for a prescribed period of time.
 6. Holiday lights and decorations.
 7. Merchandise displayed behind storefront windows so long as no part of the display moves or contains flashing lights.
 8. Memorial signs or tablets, historical markers, name of a building and dates of erection when cut into any masonry surface or when constructed of bronze or other incombustible materials and attached to the surface of a building.
 9. Signs incorporated into machinery or equipment by a manufacturer or distributor, which identify or advertise only the product or service dispensed by the machine or equipment, such as signs customarily affixed to vending machines, newspaper racks, telephone booths and gasoline pumps.
 10. Advertising and identifying signs located on taxicabs, buses, trailers, trucks or vehicle bumpers.
 11. Public warning signs to indicate the dangers of trespassing, swimming, animals or similar hazards.
 12. Works of art that do not constitute advertising.
 13. Signs carried by a person.

Section 21.05. Prohibited Signs

- A. It shall be unlawful to erect, cause to be erected, maintain or cause to be maintained, any sign not expressly authorized by, or exempted from, these regulations. The following signs are expressly prohibited unless otherwise exempted or expressly authorized by this Article:
1. Any sign with a sign face area greater than two hundred (200) square feet.
 2. Signs that are in violation of the building code or electrical code adopted by the City of Montevallo.
 3. Any sign that, in the opinion of the Administrator, does or will constitute a safety hazard.
 4. Portable signs or trailer signs.
 5. Signs with visible moving, revolving, or rotating parts or visible mechanical movement of any description or other apparent visible movement achieved by electrical, electronic, or mechanical means, except for traditional barber poles.
 6. Signs with lights or illuminations that flash, move, rotate, scintillate, blink, flicker or vary in intensity or color except for "time and temperature" signs or signs that identify the price of fuel at a service station or convenience store.

7. Strings of light bulbs used on commercially developed parcels for commercial purposes, other than traditional holiday decorations.
8. Wind signs consisting of one or more banners, flags, pennants, ribbons, spinners, streamers or captive balloons, or other objects or material fastened in such a manner as to move freely upon being subjected to pressure by wind.
9. Signs that incorporate projected images, emit any sound that is intended to attract attention, or involve the use of live animals.
10. Signs that emit audible sound, odor, or visible matter such as smoke or steam.
11. Signs or sign structures that interfere in any way with free use of any fire escape, emergency exit, or standpipe, or that obstruct any window to such an extent that light or ventilation is reduced to a point below that required by any provision of these regulations or any other regulation of the City of Montevallo.
12. Signs that resemble any official sign or marker erected by any governmental agency, or that by reason of position, shape or color, would conflict with the proper functioning of any traffic sign or signal, or be of a size, location, movement, content, color or illumination that may be reasonably confused with or construed as, or conceal, a traffic-control device.
13. Signs that obstruct the vision of pedestrians, cyclists, or motorist traveling on or entering public streets.
14. Non-governmental signs that use the words "stop," "look," "danger" or any similar word, phrase or symbol.
15. Signs, within ten (10) feet of public right of way or one hundred (100) feet of traffic-control lights, that contain red or green lights that might be confused with traffic control lights.
16. Signs that are of such intensity or brilliance as to cause glare or impair the vision of any motorist, cyclist or pedestrian using or entering a public way, or that are a hazard or a nuisance to occupants of any property because of glare or other characteristics.
17. Signs that contain any lighting or control mechanism that causes unreasonable interference with radio, television or other communication signals.
18. Signs that are painted, pasted, or printed on any curbstone, flagstone, pavement, or any portion of any sidewalk or street, except house numbers and traffic control signs.
19. Signs placed upon benches, bus shelters or waste receptacles, except as may be authorized in writing.
20. Signs erected on public property or on private property located on public property (such as private utility poles) other than signs erected by a public authority for public purposes or as otherwise permitted by these regulations.
21. Signs erected over or across any public street except as may otherwise be expressly authorized by these regulations and except governmental signs erected by or on the order of a public officer.
22. Roof signs placed above the roofline of a building or on or against a roof slope of less than forty-five (45) degrees.
23. Vehicle signs with a total sign area in excess of ten (10) square feet when the vehicle is parked for more than sixty consecutive minutes within one hundred (100) feet of any street right-of-way; is visible from the street right-of-way that the vehicle is within one hundred (100) feet of; and is not regularly used in the conduct of the business advertised on the vehicle. A vehicle used primarily for advertising shall not be considered a vehicle used in the conduct of the business.
24. Pylon or pole signs are prohibited.

Section 21.06. Permitted Signs

A. Generally

The signs enumerated in this section shall be subject to all the terms of this Article including the requirement that a sign permit be obtained prior to erection of any sign. Exemption from the requirement to obtain a sign permit does not necessarily indicate exemption from any other requirement or permit that may be required by this or any other agency.

B. All Parcels

1. **Directional Signs.** Directional signs limited in area to four (4) square feet, giving directions to motorists regarding the location of parking areas and access drives shall be permitted on all parcels and shall not be counted as part of an occupant's allowable sign area.
2. **Flags.** Not more than three flags or insignias of governmental, religious, charitable, fraternal or other organizations or institution may be displayed on any one parcel of land. Such flags shall not exceed sixty (60) square feet in area and shall not be flown from a pole the top of which is more than forty (40) feet in height. All flags must be flown in accordance with protocol established by the Congress of the United States for the Stars and Stripes. Any flag not meeting the above requirements shall be considered a banner and shall be subject to the appropriate regulations.
3. **Utility Signs.** Public utility signs that identify the location of underground utility lines and facilities, high voltage lines and facilities, and other utility facilities and appurtenances are permitted so long as they do not exceed three (3) feet in height, and so long as the sign face does not exceed two (2) square feet.

C. Undeveloped Parcels

Undeveloped parcels may display one (1) square foot of signage per ten (10) feet of frontage up to a maximum of ninety-six (96) square feet. No individual sign shall exceed sixty-four (64) square feet nor exceed ten (10) feet in height. Signs must be spaced at least one hundred (100) feet apart.

D. One-Family and Two-Family Residences

A parcel on which is located a single one-family or two-family residence may display not more than two (2) signs with an aggregate sign area of not more than ten (10) square feet. No individual sign shall exceed six (6) square feet nor exceed four (4) feet in height.

E. Three-Family and Four-Family Residences

A parcel on which is located a single three-family or four-family residence may display not more than four (4) signs with an aggregate sign area of not more than sixteen (16) square feet. No individual sign shall exceed six (6) square feet nor exceed four (4) feet in height.

F. Residential Developments, Farms and Ranches

1. A sign may be displayed at the entrance to a residential development, farm or ranch subject to the following restrictions. One (1) sign is permitted at only one entrance from each abutting street. The sign may be a single sign with two (2) faces of equal size or may be two (2) single-faced structures of equal size located on each side of the entrance. No face of the sign shall exceed thirty-two (32) square feet in size, and may be illuminated in a steady light only.
2. All such signs shall be maintained perpetually by the developer, the owner of the sign, a pertinent homeowners association or some other person who is legally accountable. Such accountability is required before a permit shall be issued. If, following the issuance of a permit and subsequent erection of such signs, no accountable person accepts legal responsibility to maintain the signs and no other provision has been made for maintenance, the signs shall be removed by the developer or owner.

G. Commercially Developed Parcels

1. **Freestanding Signs.**

Signs may be placed in a freestanding location on a commercially developed parcel subject to the following limitations:

- a. The permissible number, area, spacing and height of freestanding signs for each multiple occupancy complex and each commercial occupant not located in a multiple occupancy complex shall be determined according to Table 21.4.

	If the frontage on a public right-of-way is:					
	<=50'	>50' & <=100'	>100' & <=200'	>200' & <=300'	>300' & <=400'	>400'
Maximum number of signs	1	1	1	1	2	3
Maximum total sign area	16	32	48	64	80	96
Maximum sign area for individual sign	16	32	48	64	80	96
Minimum setback from side property line	10	15	20	50	50	50
Minimum distance from any other freestanding sign on the same site	n/a	n/a	n/a	n/a	100	100
Maximum height	10	10	10	10	10	10

Table 21.4.

- b. Multiple Frontages. For a parcel having frontage on two (2) or more public streets, each frontage shall be considered separately for the purposes of determining compliance with the above provisions for freestanding signs, but the permitted sign area for one (1) frontage may not be combined with that permitted on another frontage to increase the permitted sign area on one frontage. However, no freestanding sign on one right-of-way may be closer than one hundred (100) feet to a sign on another right-of-way.

2. Building Signs.

Signs not expressly prohibited by this Article may be attached to the wall of a building on a commercially developed parcel subject to the following limitations:

- a. Building signs shall be limited to a maximum height of thirty (30) feet above grade, except that on a building of more than thirty (30) feet in height, a single sign is allowed above thirty (30) feet on each side of the building.
- b. Each multiple occupancy complex may display one (1) building sign on each side of the principal building or buildings in the complex, not to exceed a sign face area of two hundred (200) square feet or five (5) percent of the facade area of the building side, whichever is smaller.
- c. Each occupant of a multiple occupancy complex may display three (3) building signs on any exterior portion of the complex that is part of the occupant's unit, not including common or jointly owned portions, not to exceed a sign face area of two hundred (200) square feet each or a total combined sign face area of ten (10) percent of the facade area of such exterior portion, whichever is smaller.
- d. Each occupant not located in a multiple occupancy complex may display three (3) building signs on each side of the building in which the occupant is located, not to exceed a sign face

area of two hundred (200) square feet each or a total combined sign face area of ten (10) percent of the facade area of the building side, whichever is smaller.

- e. **Time and Temperature Signs.** Time and temperature signs are permitted on commercially developed parcels notwithstanding a general prohibition on changing or animated signs. These signs may only display numerical information and must be kept accurate. They may be freestanding or attached to a building and are subject to the regulations applicable to such signs. They shall be counted as part of the occupant's allowable sign area.

Section 21.07. Design, Construction, Location and Maintenance Standards

A. Compliance with Building and Electrical Codes Required

All permanent signs, and the illumination thereof, shall be designed, constructed and maintained in conformity with applicable provisions of the building and electrical codes adopted by the City of Montevillo. Wherever there is inconsistency between these sign regulations and the building or electrical code, the more stringent requirement shall apply.

B. Illumination Standards

1. Sign lighting may not be designed or located to cause confusion with traffic lights.
2. Illumination by floodlights or spotlights is permissible so long as none of the light emitted shines directly onto an adjoining property or into the eyes of motorists or pedestrians using or entering public streets.
3. Illuminated signs shall not have lighting mechanisms that project more than eighteen (18) inches perpendicularly from any surface of the sign over public space.

C. Placement and Clearance Standards

Signs shall be located such that there is at every intersection or driveway, a clear view between heights of three (3) and ten (10) feet in a triangle formed by the corner and points on the curb seventy (70) feet from the intersection or entranceway.

1. Supports for signs or sign structures shall not be placed in or upon a public right of way or public easement, except under the terms of a lease between the owner of the easement or right of way and the owner of the sign.
2. No freestanding sign shall project over a public right of way.
3. No sign or sign structure shall be erected that impedes use of any fire escape, emergency exit, or standpipe.
4. All signs over pedestrian ways shall provide a minimum of seven (7) feet six (6) inches of clearance.
5. All signs over vehicular ways shall provide a minimum of thirteen (13) feet six (6) inches of clearance.
6. No sign or sign structure shall be erected that impedes an unobstructed visibility at a level three (3) feet above the road, measured from the street grade at the center of the closest traffic lane.

D. Relationship to Building Features

1. A building sign shall not extend beyond any edge of the surface to which it is attached, nor disrupt a major architectural feature of the building.
2. A building sign may project no more than four (4) feet perpendicularly from the surface to which it is attached.
3. The combined area of permanent and temporary signs placed on or behind windows shall not exceed twenty-five (25) percent of the total window area at the same floor level on the side of the building or unit upon which the signs are displayed.

E. Maintenance

All signs, including their supports, braces, guys and anchors, electrical parts and lighting fixtures, and all painted and display areas, shall be maintained in accordance with the building and electrical codes adopted by City of Montevallo, and shall present a neat and clean appearance. The vegetation around, in front of, behind, and underneath the base of freestanding signs for a distance of ten (10) feet shall be neatly trimmed and free of unsightly weeds, and no rubbish or debris that would constitute a fire or health hazard shall be permitted under or near the sign.

Section 21.08. Administration.

A. Permits

1. Applicability.

No person shall erect a sign without first obtaining a sign permit therefore, except for the following actions which shall not require a permit:

- a. Changing the copy, announcement or message on a sign;
- b. Cleaning, painting, electrical or comparable maintenance or repair of a sign that does not alter any regulated feature of such sign;
- c. Erecting a sign for which a permit is not required in accordance with §21.04 Exempt Signs or §21.06 (A) Permitted Signs - Generally.

2. Procedure.

All sign permits shall be procured in accordance with the following procedure:

- a. A written application shall be submitted to the Administrator for review and processing. The application will be accepted by the Administrator only upon determination that all requisite documentation and fees accompany the application form. The application shall include such supplementary information as may be specifically requested by the Administrator to determine compliance with these regulations.
- b. The Administrator shall review the application and plans and specifications to determine whether the proposed sign conforms to all applicable requirements of these regulations.
- c. Following review and determination as to conformance with these regulations, the Administrator shall, in a reasonably expeditious manner, either approve or deny the application for the sign permit. In case of denial, the Administrator shall specify the section or sections of these regulations with which the proposed sign is not in conformance.
- d. If an approved sign requires a building permit, the Administrator shall forward a copy of the completed application form and associated plans and specifications to the building official who shall determine whether the proposed sign conforms to all applicable requirements of the building regulations and who shall, in a reasonably expeditious manner, either approve or deny an application for a permit to construct the sign.

3. Submission Requirements.

No request for a sign permit shall be considered complete until all of the following has been submitted to the Administrator:

a. Application Form.

The application shall be submitted to the Administrator in duplicate on forms made available by the City.

b. Statement of Authorization.

Any application form which is signed by an individual other than the property owner shall be accompanied by a notarized statement of authorization consenting to the sign placement or, if the property or building upon which the sign is to be located is leased, evidence of the executed lease shall accompany the application form. In the event the building or property is leased and the application form is signed by an individual other than the lessor, the application shall be accompanied by a notarized statement of authorization signed by the

lessor consenting to the sign placement and evidence of the executed lease.

c. Plans and Specifications.

Plans and specifications for any proposed sign shall be submitted in duplicate, drawn to scale and include the following:

- 1) lot frontage on all street rights-of-way;
- 2) facade area of any wall on which a sign is proposed to be placed;
- 3) dimensions and elevations (including the message) of the sign;
- 4) dimensions of the sign's supporting members;
- 5) maximum and minimum height of sign, as measured from finished grade;
- 6) location of the sign in relation to property lines, public rights-of-way, easements, buildings, and other signs on the property;
- 7) for illuminated signs, the type, placement, intensity and hours of illumination;
- 8) construction and electrical specifications, for the purpose of enabling determination that the sign meets all applicable structural and electrical requirements of the building code;
- 9) value of the proposed sign;
- 10) number, type, location and surface area of all existing signs on the same property and/or building on which the sign is to be located.

d. Application Fee.

The applicant shall be required to pay an application fee according to the current schedule of fees established by the City Council for the particular category of the application. This fee shall be nonrefundable irrespective of the final disposition of the application.

e. Permit Expiration.

Sign permit shall be valid for a maximum of sixty (60) days after issuance. Failure to place the sign within the allotted time period shall void the permit and necessitate reapplication.

Section 21.09. Variance.

Any request for a variance from the standards set forth in this Article shall be processed according to the procedures and criteria set forth in Article 26 of this Ordinance.

Section 21.10. Inspections.

The Administrator shall, as each may determine necessary, inspect the property to ascertain that the sign is in accord with all provisions of these regulations and the building regulations, respectively, and in accord with all terms upon which the sign permit may have been conditioned.

Section 21.11. Nonconforming Signs.

- A. A nonconforming sign is any sign within the jurisdiction of the City of Montevallo on the effective date of this Article or any sign existing within any area added to such jurisdiction after the effective date of this Article which is prohibited by or does not conform to the requirements of these regulations.
- B. Subject to the limitations imposed by § 21.13 below, a nonconforming sign may be continued and shall be maintained in good condition as required by these regulations, but it shall not be:
 1. Structurally changed to another nonconforming sign, but its pictorial content may be changed.
 2. Structurally altered to prolong the life of the sign, except to meet safety requirements.
 3. Expanded or altered in any manner that increases the degree of nonconformity.
 4. Re-established after damage or destruction if the estimated cost of reconstruction exceeds fifty (50) percent of the appraised replacement cost as determined by the Administrator.

5. Continued in use when a conforming sign or sign structure shall be erected on the same parcel or unit.
6. Continued in use when the structure housing the occupancy is demolished or requires renovations the cost of which exceeds fifty (50) percent of the assessed value of the structure.

Section 21.12. Abandoned Signs.

- A. Except as otherwise provided in this Article, any sign that is located on property which becomes vacant and unoccupied, or pertains to a business which does not maintain a current business license, or pertains to a time, event or purpose which is no longer applicable shall be deemed to have been abandoned. Any abandoned sign shall be prohibited and shall be removed by the owner of the sign or the owner of the property. The frame of an abandoned sign shall not be required to be removed if it conforms to all applicable terms contained in these regulations (including the sign face area for sign replacement yielded by such frame).
- B. Any sign structure which supported an abandoned sign and which structure conforms to all applicable terms contained in these regulations shall be allowed to remain in place. However, in the event a sign structure which supported or supports an abandoned sign is inconsistent with any of the terms contained in these regulations (including the sign face area for sign replacement yielded by the frame) then the sign structure and frame shall be either altered to comply with the terms contained herein or removed by the owner of such structure or the owner of the property.

Section 21.13. Illegal Signs.

- A. The following signs shall be considered to be illegal and a violation of the terms of this Article:
 1. A sign erected or maintained after the effective date of this Article that is inconsistent with the terms contained herein;
 2. A nonconforming sign which was erected inconsistent with the terms governing location, height, surface area or other regulatory measures applicable at the time of its erection;
 3. An abandoned sign.
- B. Upon determination by the Administrator that a certain sign is illegal, the Administrator shall act to remedy the violation, which may include:
 1. The issuance of a notice of violation to the individual who owns, is responsible for, or benefits from the display of such sign prescribing the action necessary to make the sign legal and conforming to the terms contained herein or ordering the removal of the illegal sign and also prescribing the time which the individual is afforded to accomplish such action;
 2. The City shall have the right to recover from the individual responsible for any such illegal sign the full costs of removal and disposal for any such illegal sign located on public property or on private property including any such illegal sign located within a street right-of-way.
- C. Failure to bring any illegal sign into conformance with the terms contained in this Article or any other violation of the terms contained in this Article shall be considered a violation of the Zoning Ordinance of the City of Montevillo and shall be subject to the remedies and penalties provided by such Ordinance and by State Law.